



Completing Your Workspace



LEADING THE WAY IN COMPLETING YOUR WORKSPACE



Our Products

With ergonomics as our template, our products are designed to improve productivity in the workplace. These products provide user-friendly solutions to common problems found in most offices that use computers.

Our Quality

Our quality control systems ensure completeness and accuracy of product deliveries.

Our Warranty

Most of ISE's products carry a limited lifetime warranty. We quickly resolve issues with minimal 'red tape'.

Our Services

All ISE products are sold by contract furniture dealers. These dealers are supported by independent, factory trained representatives. This ensures the workplace is properly evaluated for correct products that are then delivered, installed and after sales serviced.

Our Lead Time

Many of ISE's products are available on a 48 hour Quickship. The majority of products are shipped within 2 weeks of order receipt.



Completing Your Workspace

TABLE OF CONTENTS

■	8 POINT ERGONOMIC CHECKLIST	4
■	LEADER - ERGONOMIC ESSENTIALS	
■	UNIQUE FEATURES & INNOVATIVE SYSTEMS	5
■	LEADER SERIES - HEALTHY COMPUTING PRODUCTS	6 - 8
■	ACCESS - ORGANIZATION TOOLS	9
■	KAZI - PERSONAL CONTROL LIGHTING	10 - 11
■	OMERO - VISUAL ERGONOMICS	12 - 13
■	SHIFT - ADJUSTABLE TABLES	14 - 15
■	CENTEX - FURNISHING INTENSIVE TECHNOLOGY	16 - 17
■	SIT-RITE - INTELLIGENT USE SEATING	18 - 19

8 POINT ERGONOMIC CHECKLIST - SEMI RECLINED POSITION

- ① HEAD • EYE LEVEL WITH THE TOP LINE OF MONITOR
- ② SHOULDERS AND HIPS • IN LINE WITH EACH OTHER
- ③ WRISTS • IN NEUTRAL POSITION
- ④ LUMBAR SUPPORT • SMALL OF BACK SHOULD COINCIDE WITH THE LUMBAR CURVE OF THE CHAIR
- ⑤ THIGH ALIGNMENT • KNEES SLIGHTLY LOWER THAN HIPS
- ⑥ ARMREST HEIGHT • FOREARMS AND/OR ELBOWS SHOULD BE POSITIONED COMFORTABLY ALONG THE CHAIRS ARMREST TO AVOID CONSTANT LIFTING OF THE SHOULDERS OR LEANING TO THE SIDE
- ⑦ SEAT PAN ANGLE • SHOULD NOT BE AT AN ANGLE OF LESS THAN 90°
- ⑧ FEET • FLAT ON FLOOR OR ON FOOTREST

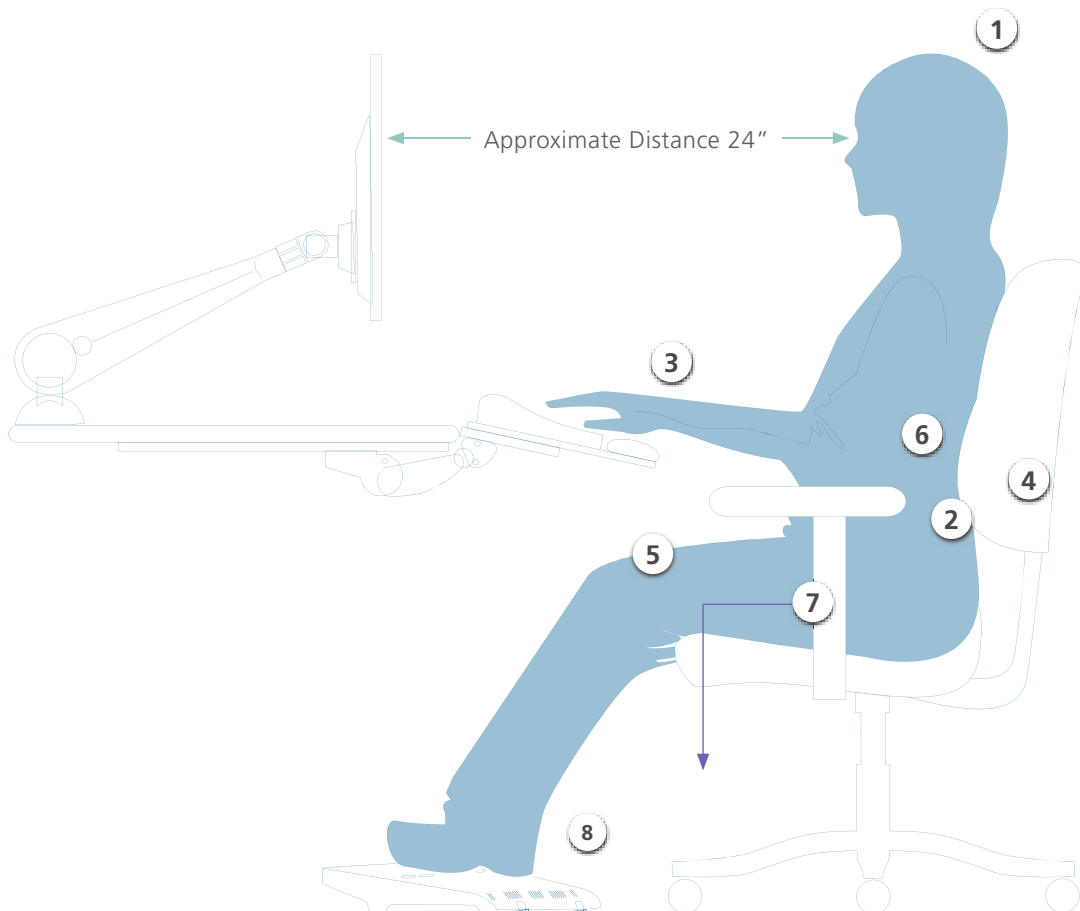

Leader Series

UNIQUE FEATURES & INNOVATIVE SYSTEMS

Connect[™] it

INSTANT, TOOL-LESS INSTALLATION

Leader Boards can be installed, and interchanged in seconds with ISE'S unique **Connect it** system.

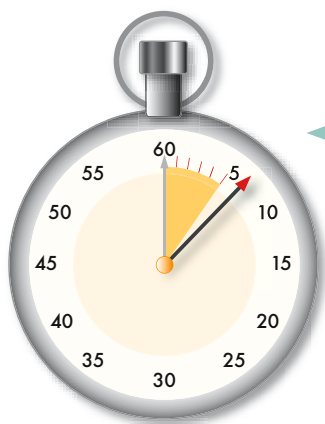

← Connect It! in seconds with ISE's Leader Boards

UniVERSAL PLATFORM TECHNOLOGY

ANY KEYBOARD

Rectangular, Microsoft or other internet/ergo curved keyboards.

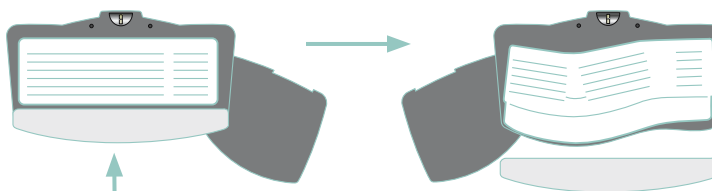

Curved front under Removable Palm Pad

POSTURE TILT INDICATOR

The **only** keyboard platform with an intuitive guide to achieve correct postures throughout the day.

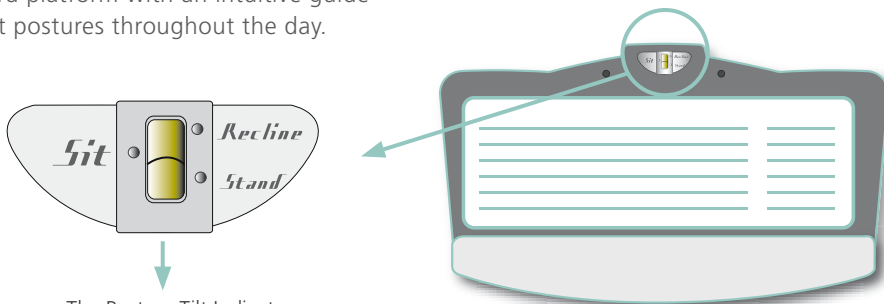

The Posture Tilt Indicator is placed at the top of all Leader Boards

Leader Series

- 1 Leader Board SKATE - same plane mousing surface
- 2 Dial-a-Leader arm enables you to sit, stand or recline
- 3 Leader Board CURVED - same plane mousing surface
- 4 Leader Board STRAIGHT - same plane mousing surface
- 5 Leader Board DIAGONAL - same plane mousing surface

KEYBOARD SOLUTIONS

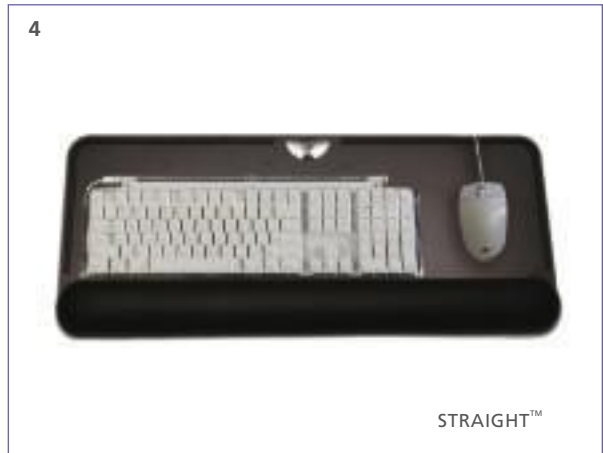

LEADER ARMS & PLATFORMS

1 Leader Board
SWIVEL - movable mouse
plane surface

3 Detail -
Leader SHORT Arm

2 Leader Board
SWING - movable mouse
plane surface



Leader Series

OTHER HEALTHY SOLUTIONS

1 The JACK - allows you to use your laptop as an external monitor

3 FEET FIRST - Footrest

2 M BOARD - Converts a 90° corner into a diagonal allowing mounting of an articulating arm

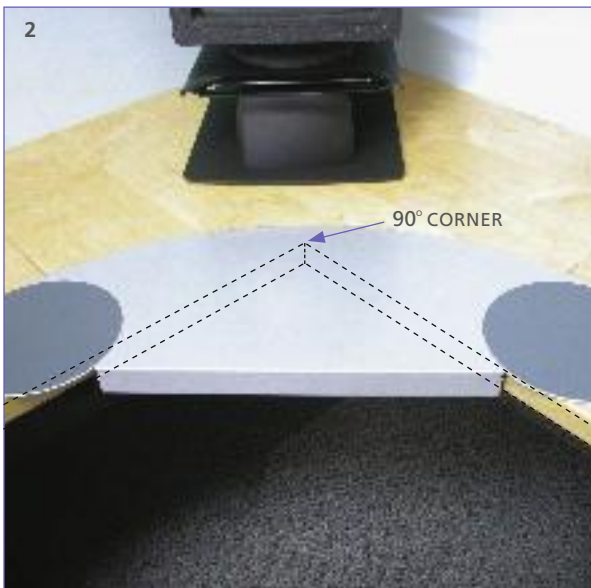
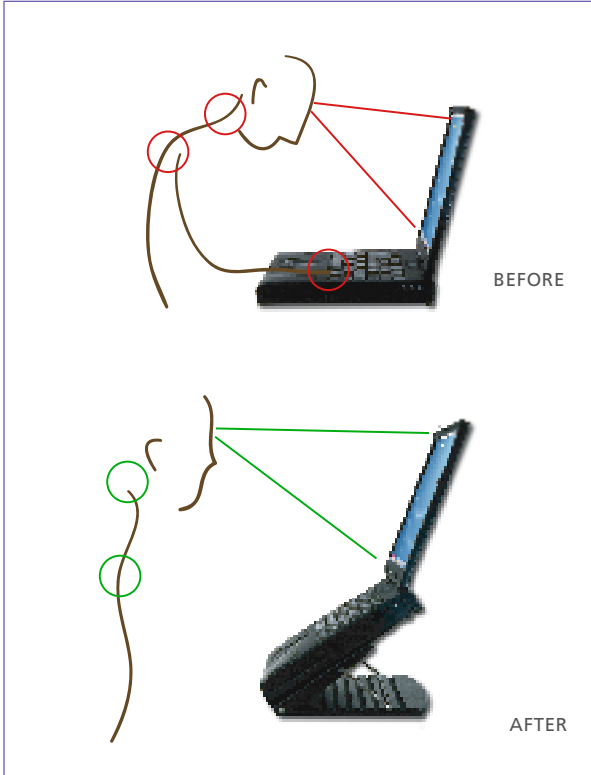

ACCESS™

- 1 ACCESS - Accessory tray
- 2 ACCESS - CD holder
- 3 ACCESS - Folder tray
- 4 ACCESS - Pencil cup
- 5 ACCESS - CPU Holder
- 6 ACCESS - Binder holder
- 7 ACCESS - CPU Trolley
- 8a & b ACCESS - Retractable Personal Storage

ACCESSORIES FOR YOUR WORK AREA

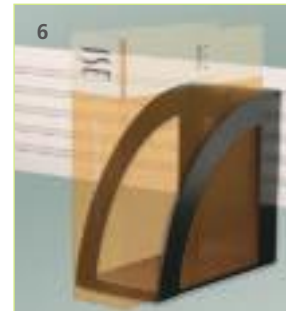
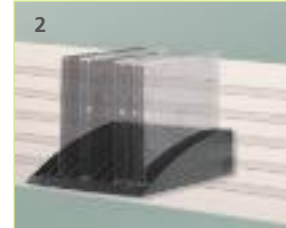



- 1 Kazi KINETIC - Dual Arm Desk Task Light
- 2 Kazi KINETIC - Single Arm Panel Mount Task Light
- 3 Kazi KINETIC - Glide Light

TASK LIGHTING



1 KAZI - KALEIDESCOPE
Magnet Mount Task Light

3 KAZI - KALEIDESCOPE

2 KAZI - KWALITY
Under Mount Task Light



OMERO™

1 OMERO - Monitor Arm
MA 2003 - single

2 OMERO - Monitor Arm
MA 2003 - dual

3 OMERO - Monitor Arm
MA 2003 - triple

4 OMERO - Monitor Arm
MA 2003 - quadruple

5 OMERO - Monitor Arm
MA 2003 - sextuple

FLAT PANEL MONITOR ARMS



1 OMERO - Space Saver Copy Holder

2 OMERO - Single Monitor Arm

3 OMERO - Copy Holder

4 OMERO - Monitor Riser with Swivel Tray

5 OMERO - Monitor Riser

6 OMERO - Writing Tablet

FLAT PANEL MONITOR ARM, COPY HOLDERS & MONITOR RISERS



Shift™

- 1 Shift - Rectangular Table with polished chrome base
- 2 Shift - Oval Table with black base

TRAINING, MOBILE & HEIGHT ADJUSTABLE TABLES



- 1 Shift - Split Surface Corner Electric Adjustable Table
- 2 Shift - Fold Under Monitor Training Table

- 3 Shift - Folding Table
- 4 Shift - Electric Adjustable 'Bi-Wing' Table

- 5 Shift - Electric Adjustable Rectangular Table



CENTEX

1 CENTEX - Corner Station Typical

3 CENTEX - FIT Training Table

2 CENTEX - Dual Station Typical

FURNITURE ADAPTABLE TO YOUR WORK NEEDS

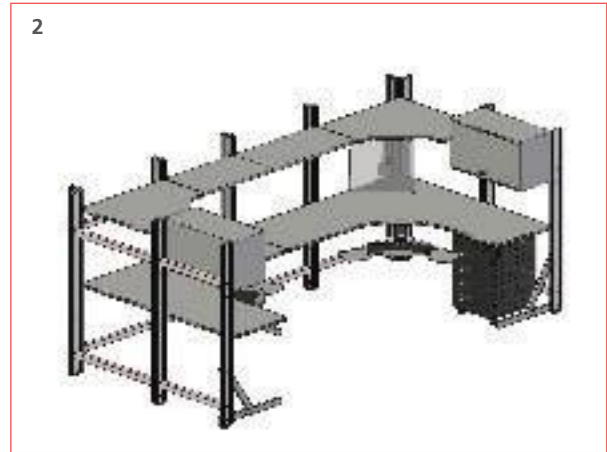
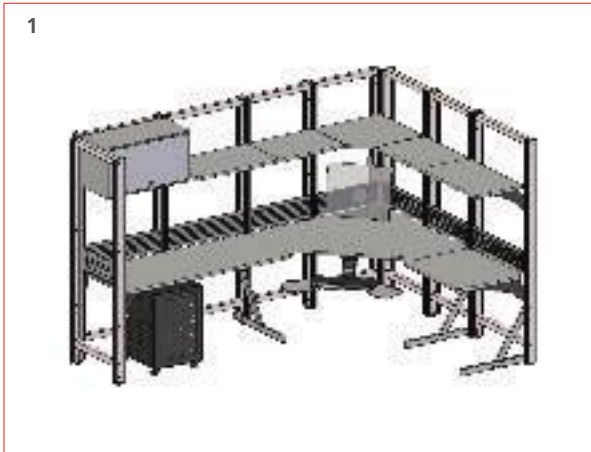

- 1 CENTEX - Multi-Level Typical
- 2 CENTEX - In-line-Grouping Station Typical

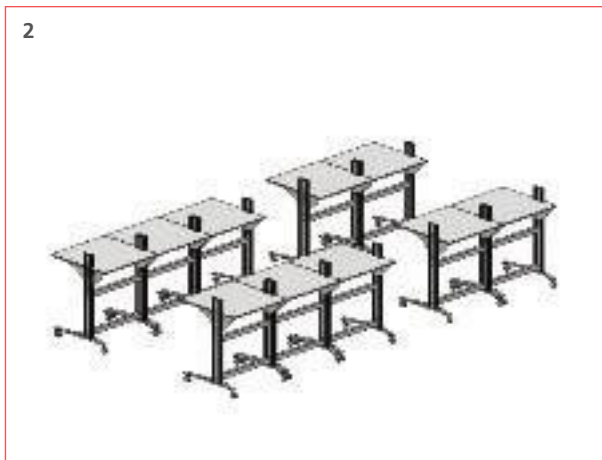
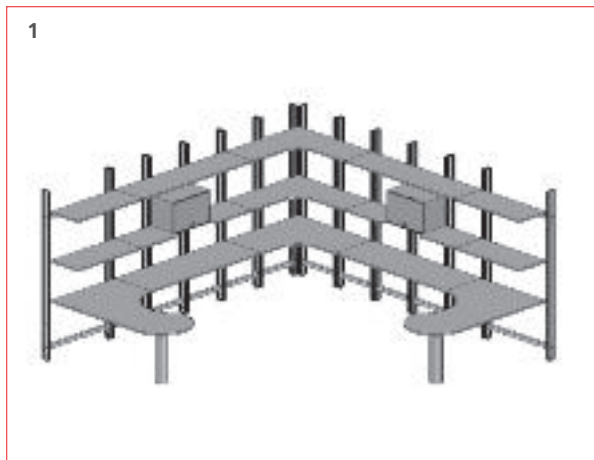

Sit-Rite™

1 Sit-Rite - Vertex Bench-height Stool

3 Sit-Rite - Classic Cleanroom Class I Stool

2 Sit-Rite - Vertex ESD Chair

TECHNICAL SEATING



1 Sit-Rite - SIT-STAND Stool

2 Sit-Rite - Task Stool

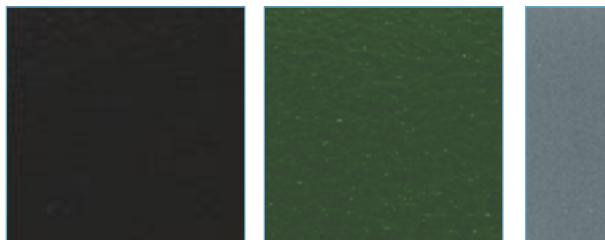
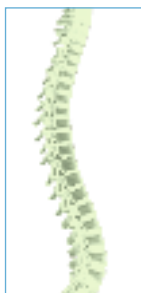

1



2





ISE Head Office & Showroom 950 Warden Avenue Toronto, ON M1L 4E3	Client Services T: 1.800.463.7731 F: 1.800.461.3182 E: info@ise-ergo.com W: www.ise-ergonomics.com
--	--

For more information - specifications,
prices, order codes - call us or check
our comprehensive website.